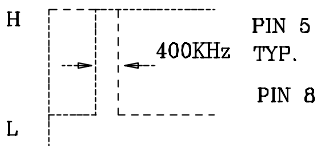
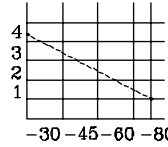

SPECIFICATION			
<p>CONTENTS</p> <p>1.GENERAL SPECIFICATION</p> <p>2.STANDARD TEST CONDITION</p> <p>3.CURRENT CONSUMPTION</p> <p>4.ABSOLUTE MAXIMUM VOLTAGE AND CURRENT</p> <p>5.ELECTRICAL SPECIFICATION</p>			
NO.	ITEM	SPECIFICATION	NOTE
1.	GENERAL SPECIFICATION		
1-1.	INPUT FREQUENCY RANGE	2.4GHz~2.4835GHz	
COMTECH TECHNOLOGY CO., LTD			FM2400RTIM6 (1/5)

SPECIFICATION													
NO.	ITEM	SPECIFICATION	NOTES										
1-3.	ONE INPUT CONNECTOR	SMA CONNECTOR	SP5055 (PLESSEY) TA8804F										
1-4.	NOMINAL INPUT IMPEDANCE	75 OHM											
1-5.	TUNING CIRCUIT	BUILT IN PLL											
1-6.	IF FREQUENCY	479.50 MHz CENTER											
1-7.	IF BAND WIDTH	16 MHz NOMINAL (SELECTABLE)											
1-8.	DEMODULATION	PHASE LOCKED LOOP											
1-9.	VEDIO OUTPUT POLARITY	NEGATIVE											
1-10.	OPERATING VOLTAGE	+28V (+/-5%) +5V (+/-5%)											
1-11.	OPERATING TEMPERATURE	-10°C ~ +60°C											
1-12.	OPERATING HUMIDITY	LESS THAN 80% R.H. (AT 40°C)											
1-13.	STORAGE TEMPERATURE	-20°C ~ +70°C											
1-14.	STORAGE HUMIDITY	LESS THAN 95% R.H. (AT 40°C)											
2.	STANDARD TEST CONDITION	TEST FOR ELECTRICAL SPECIFICATION SHALL BE PREFORMED AT FOLLOWING CONDITION UNLESS OTHERWISE SPECIFIED.											
2-1.	AMBIENT CONDITION	TEMPERATURE 25°C +/- 2°C HUMIDITY 65% +/- 5% R.H. IF NO DOUBT ON TEST RESULTS, TEMPERATURE +5°C ~ +30°C AND HUMIDITY 45% ~ 80% R.H. COULD BE APPLIED.											
2-2.	MEASUREMENT TO START	30 MINUTES AFTER DC POWER SUPPLIED.											
2-3.	POWER SUPPLY	<table border="1"> <thead> <tr> <th>TERMINAL</th> <th>SUPPLY VOLTAGE</th> </tr> </thead> <tbody> <tr> <td>+5V</td> <td>+5V(+/-)0.1V</td> </tr> <tr> <td>+12V</td> <td>+12V(+/-)0.1V</td> </tr> <tr> <td>SDA</td> <td>SPECIFIED TUNING</td> </tr> <tr> <td>SCL</td> <td>PULSE</td> </tr> </tbody> </table>	TERMINAL	SUPPLY VOLTAGE	+5V	+5V(+/-)0.1V	+12V	+12V(+/-)0.1V	SDA	SPECIFIED TUNING	SCL	PULSE	
TERMINAL	SUPPLY VOLTAGE												
+5V	+5V(+/-)0.1V												
+12V	+12V(+/-)0.1V												
SDA	SPECIFIED TUNING												
SCL	PULSE												

SPECIFICATION																					
NO.	ITEM	SPECIFICATION				NOTES															
3.	CURRENT CONSUMPTION	<table border="1"> <thead> <tr> <th>TERMINAL</th> <th>MIN.</th> <th>TYP.</th> <th>MAX.</th> <th></th> </tr> </thead> <tbody> <tr> <td>+5V</td> <td>190</td> <td>240</td> <td>290</td> <td>mA</td> </tr> <tr> <td>+12V</td> <td>0.5</td> <td>1.0</td> <td>3.0</td> <td>mA</td> </tr> </tbody> </table>	TERMINAL	MIN.	TYP.	MAX.		+5V	190	240	290	mA	+12V	0.5	1.0	3.0	mA				
TERMINAL	MIN.	TYP.	MAX.																		
+5V	190	240	290	mA																	
+12V	0.5	1.0	3.0	mA																	
4.	ABSOLUTE MAXIMUM VOLTAGE	<table border="1"> <thead> <tr> <th>TERMINAL</th> <th>MAX. SUPPLY VOLTAGE</th> </tr> </thead> <tbody> <tr> <td>+5V</td> <td>DC +5.25V</td> </tr> <tr> <td>+12V</td> <td>DC +30V</td> </tr> <tr> <td>SDA,SCL</td> <td>OV TO THE SAME VOLTAGE AS +5V TERMINAL</td> </tr> </tbody> </table>	TERMINAL	MAX. SUPPLY VOLTAGE	+5V	DC +5.25V	+12V	DC +30V	SDA,SCL	OV TO THE SAME VOLTAGE AS +5V TERMINAL											
TERMINAL	MAX. SUPPLY VOLTAGE																				
+5V	DC +5.25V																				
+12V	DC +30V																				
SDA,SCL	OV TO THE SAME VOLTAGE AS +5V TERMINAL																				
		<table border="1"> <thead> <tr> <th>TERMINAL</th> <th>MAX. TAKE OFF CURRENT</th> </tr> </thead> <tbody> <tr> <td>B.B OUTPUT</td> <td>0.5mA</td> </tr> </tbody> </table>	TERMINAL	MAX. TAKE OFF CURRENT	B.B OUTPUT	0.5mA															
TERMINAL	MAX. TAKE OFF CURRENT																				
B.B OUTPUT	0.5mA																				
5.	ELECTRICAL SPECIFICATION	UNDER STANDARD TEST CONDITION TEST CHANNEL : DBS 20 CH INPUT LEVEL : -45dBm UNLESS OTHERWISE SPECIFICIED.																			
		CONDITION	MIN.	TYP.	MAX.																
5-1.	INPUT VSWR	2.4~2.4835GHz		2.0	3.0																
5-2.	NOISE FIGURE	2.4~2.4835GHz		3.5		AGC FULLGAIN dB															
5-3.	LOCAL LEAKAGE AT INPUT TERMINAL	1920.5~2.004GHz			-63.0	dBm															
5-4.	TUNING VOLTAGE CURVE	2.4GHz~2.4835GHz	5V		10V	V															
5-5.	LOCAL OSCILLATOR +B SHIFT	TUNING VOLTAGE SHIFT WITH +B +/- 5%			± 0.8	WITH TUNING PLL LOCKED															
5-6.	LOCAL OSCILLATOR TEMPERATURE DRIFT	TUNING VOLTAGE SHIFT WITH -10°C~+60°C			± 1.3	V															
5-7.	IF 3dB BAND WIDTH	3dB DOWN		16		MHz															
COMTECH TECHNOLOGY CO., LTD						FM2400RTIM6 (3/5)															

SPECIFICATION						
NO.	ITEM	SPECIFICATION			NOTES	
5-8.	AFT OUTPUT (2 BIT OUTPUT)					
		CONDITION	MIN.	TYP.		MAX.
		CENTER FREQUENCY ERROR(f0)	-2		+2	MHz
5-9.	B.B OUTPUT CHARACTERISTICS	VIDEO WAVEFORM WHITE 100% PAL FREQUENCY DEVIATION 8MHz _{p-p} WITHOUT PRE-EMPHASIS			V _{p-p}	
	(1) VIDEO OUTPUT LEVEL	WHITE TO SYNC.	0.72	0.90		1.12
	(2) GAIN-FREQUENCY RESPONSE	TEST MODULATION FREQUENCY :60Hz~8MHz WITHOUT ENERGY DISPOSAL MODULATION REFERENCE FREQ. 100KHz IF BW 16MHz			dB	
		FREQ. RESPONSE		± 1		± 3
	(3) GROUP DELAY RESPONSE	TEST FREQUENCY :60Hz~8MHz WITHOUT ENERGY DISPOSAL MODULATION REFERENCE FREQ. 100KHz IF BW 16MHz			nsec	
	GROUP DELAY		± 10	± 50		
(4) DG/DP	10 STEP SIAIRCASE 8MHz _{p-p} PAL WITHOUT ENERGY DISPOSAL MODULATION POSITIVE VIDEO AMPLIFIER WITH DE-EMPHASIS SHOULD BE APPLIED IF BW 16MHz			% °		
	DG (APL 50%)		4.0		8.0	
	DP (APL 50%)		3.0	5.0		
(5) SN RATIO	INPUT C/N=14dB (NOISE BW 16MHz) WHITE 100% VIDEO 8MHz _{p-p} PAL WITH AUDIO SUBCARRIER MODULATION 3.4MHz _{p-p} DEV. @6.5MHz POSITIVE VIDEO AMPLIFIER WITH DE-EMPHASIS SHOULD BE APPLIED 100Hz~5MHz UNWEIGHTED SN FOR:POWER ON RESET INDICATOR			dB		
	SN	34.0	36.0			
COMTECH TECHNOLOGY CO., LTD					FM2400RTIM6 (4/5)	

SPECIFICATION																																																																																																	
NO.	ITEM	SPECIFICATION							NOTES																																																																																								
7-1.	SIGNAL LEVEL OUT VOLTAGE	(V) SIGNAL LEVEL OUT  -30 -45 -60 -80 INPUT LEVEL (dBm)							47K Ω LOADED																																																																																								
7-2.	IIC BUS (1) SDA,SCL INPUT VOLTAGE	UNDER STANDARD TEST CONDITION FM2400RTIM6 <table border="1" style="width:100%; border-collapse: collapse;"> <thead> <tr> <th>CONDITION</th> <th>MIN.</th> <th>TYP.</th> <th>MAX.</th> </tr> </thead> <tbody> <tr> <td>HIGH VOLTAGE</td> <td>3</td> <td></td> <td>5</td> </tr> <tr> <td>LOW VOLTAGE</td> <td>0</td> <td></td> <td>1.5</td> </tr> </tbody> </table>							CONDITION	MIN.	TYP.	MAX.	HIGH VOLTAGE	3		5	LOW VOLTAGE	0		1.5	V																																																																												
CONDITION	MIN.	TYP.	MAX.																																																																																														
HIGH VOLTAGE	3		5																																																																																														
LOW VOLTAGE	0		1.5																																																																																														
	(2) ADDRESS	C2 (ON WRITE DATA FORMAT)																																																																																															
	(3) SDA SCL INPUT IMPEDANCE	SDA/SCL ARE IN THE HIGH IMPEDANCE AND THERE SHOULD BE NO RELIABILITY PROBLEM WITH 5V CONTINUALLY ON THE SDA/SCL, IF POWER SUPPLY IS SWITCHED OFF.																																																																																															
	(4) DATA FORMAT	<table border="1" style="width:100%; border-collapse: collapse;"> <thead> <tr> <th></th> <th colspan="5">MSB</th> <th colspan="5">LSB</th> </tr> <tr> <th>ADDRESS</th> <th>1</th> <th>1</th> <th>0</th> <th>0</th> <th>0</th> <th>MA1</th> <th>MA0</th> <th>0</th> <th>A</th> <th>BYTE1</th> </tr> </thead> <tbody> <tr> <td>PROGRAMMABLE DIVIDER</td> <td>0</td> <td>2</td> <td>2</td> <td>2</td> <td>2</td> <td>2</td> <td>2</td> <td>2</td> <td>A</td> <td>BYTE2</td> </tr> <tr> <td>PROGRAMMABLE DIVIDER</td> <td>7</td> <td>6</td> <td>5</td> <td>4</td> <td>3</td> <td>2</td> <td>1</td> <td>0</td> <td>A</td> <td>BYTE3</td> </tr> <tr> <td>CHARGE PUMP AND TEST BITS</td> <td>1</td> <td>CP</td> <td>T1</td> <td>T0</td> <td>1</td> <td>1</td> <td>1</td> <td>OS</td> <td>A</td> <td>BYTE4</td> </tr> <tr> <td>I/O PORT CONTROL BITS</td> <td>P7</td> <td>P6</td> <td>P5</td> <td>P4</td> <td>P3</td> <td>P2</td> <td>P1</td> <td>P0</td> <td>A</td> <td>BYTE5</td> </tr> </tbody> </table> <p style="text-align: center;">TABLE 1 WRITE DATA FORMAT (MSB IS TRANSMITTED FIRST)</p> <table border="1" style="width:100%; border-collapse: collapse;"> <thead> <tr> <th>ADDRESS</th> <th>1</th> <th>1</th> <th>0</th> <th>0</th> <th>0</th> <th>MA1</th> <th>MA0</th> <th>0</th> <th>A</th> <th>BYTE1</th> </tr> </thead> <tbody> <tr> <td>STATUS BYTE</td> <td>FOR</td> <td>FL</td> <td>I2</td> <td>I1</td> <td>I0</td> <td>A2</td> <td>A1</td> <td>A0</td> <td>A</td> <td>BYTE2</td> </tr> </tbody> </table> <p style="text-align: center;">TABLE 2 READ DATA FORMAT</p> <p>A:ACKNOWLEDGE BIT. MA1,MA0:VOLTAGE ADDRESS BITS. CP:CHARGE PUMP CURRENT SELECT. T1:TEST MODE SELECTION. T0:CHARGE PUMP DISABLE. OS:VARACTOR DRIVE OUTPUT DISABLE SWITCH. P7,P6,P5,P4,P3,P2,P1,P0:CONTROL OUTPUT STATES. POR:POWER ON RESET INDICATOR FL:PHASE LOCK DETECT FLAG. I2,I1,I0:DIGITAL INFORMATION FROM PORTS P7,P5 AND P4. A2,A1,A0:5 LEVEL ADC DATA FROM P6.</p>								MSB					LSB					ADDRESS	1	1	0	0	0	MA1	MA0	0	A	BYTE1	PROGRAMMABLE DIVIDER	0	2	2	2	2	2	2	2	A	BYTE2	PROGRAMMABLE DIVIDER	7	6	5	4	3	2	1	0	A	BYTE3	CHARGE PUMP AND TEST BITS	1	CP	T1	T0	1	1	1	OS	A	BYTE4	I/O PORT CONTROL BITS	P7	P6	P5	P4	P3	P2	P1	P0	A	BYTE5	ADDRESS	1	1	0	0	0	MA1	MA0	0	A	BYTE1	STATUS BYTE	FOR	FL	I2	I1	I0	A2	A1	A0	A	BYTE2	
	MSB					LSB																																																																																											
ADDRESS	1	1	0	0	0	MA1	MA0	0	A	BYTE1																																																																																							
PROGRAMMABLE DIVIDER	0	2	2	2	2	2	2	2	A	BYTE2																																																																																							
PROGRAMMABLE DIVIDER	7	6	5	4	3	2	1	0	A	BYTE3																																																																																							
CHARGE PUMP AND TEST BITS	1	CP	T1	T0	1	1	1	OS	A	BYTE4																																																																																							
I/O PORT CONTROL BITS	P7	P6	P5	P4	P3	P2	P1	P0	A	BYTE5																																																																																							
ADDRESS	1	1	0	0	0	MA1	MA0	0	A	BYTE1																																																																																							
STATUS BYTE	FOR	FL	I2	I1	I0	A2	A1	A0	A	BYTE2																																																																																							
COMTECH TECHNOLOGY CO., LTD									FM2400RTIM6																																																																																								
										(5/5)																																																																																							

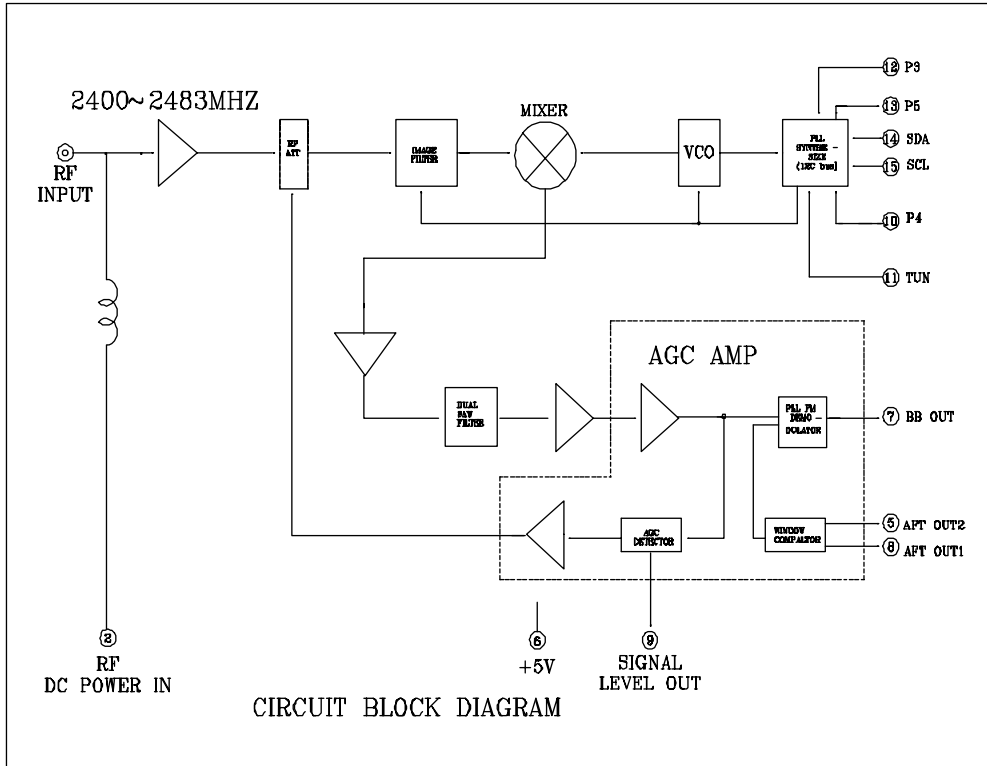

PCB LAYOUT REFERENCE POSITION:

PIN NO.	CONTENTS
1	—
2	RF DC IN MAX 25V
3	—
4	—
5	APT OUT (DIGITAL)
6	+5V
7	BB OUT
8	APT OUT (DIGITAL)
9	SIGNAL LEVEL OUT
10	P4
11	12~28V
12	P3
13	P5
14	SDA
15	SCL

**NOTE 1. TOLERANCES ARE ±0.5.
UNLESS OTHERWISE SPECIFIED.**

CUSTOM MODEL

COMTECH MODEL FM2400RTIM6

DATE	DESIGNER	COMTECH TECHNOLOGY CO., LTD.
CHKD.	DATE	SCALE
APPV.	REV.	TITLE
CONFORM ONE OF IEC APPROVED	DATE	FORM NO.